

QL-12B-1 load cells are available in the capacities from 100kg to 500kg.

Alloy aluminum construction with parallel beam type.

Silicon adhesive sealed, surface anodized and anti-corrosion.

Integral structure and easy installation.

Suitable for electronic counting scales, platform scales, electronic balance and other electronic weighing devices.



Features:

Capacity : 100kg to 500kg

Defend grade:IP65

High accuracy.

Alloy aluminum parallel beam

Max. platform size:400x400mm

Integral structure, reliable performance, and easy installation

Electrical connection and Dimensions:

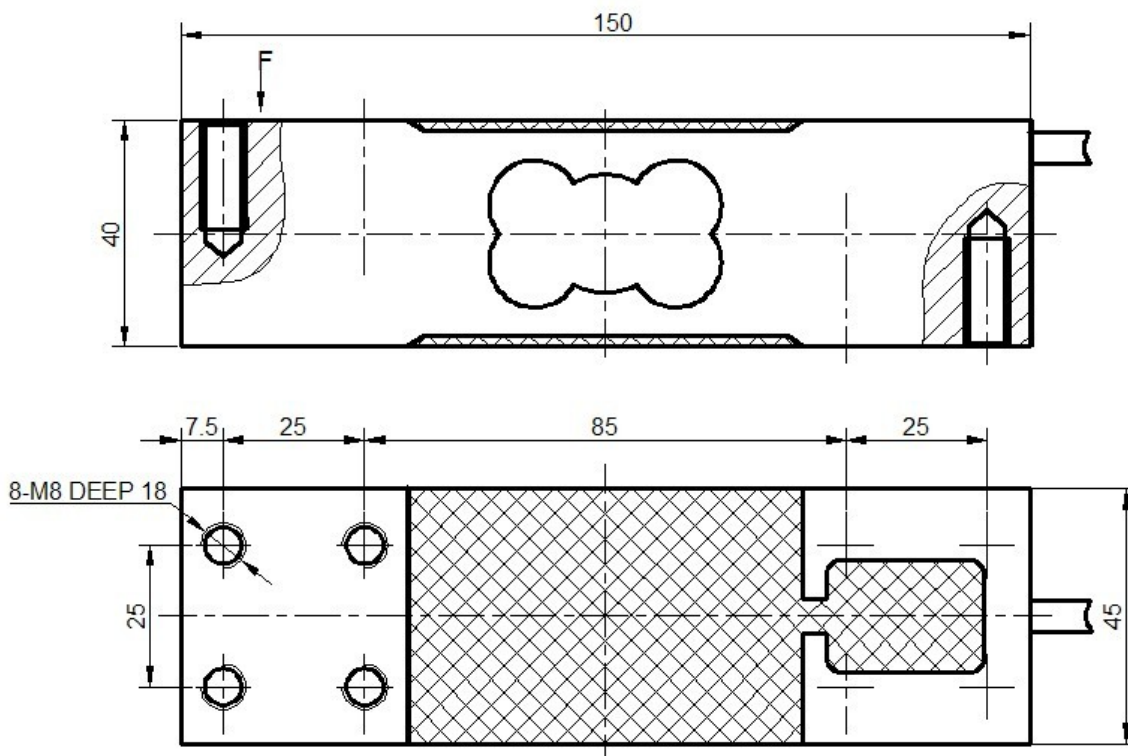

Technical Specifications

Specifications:		
capacity	kg	100,150,200,250,300,500
safe overload	%FS	120
ultimate overload	%FS	150
rated output	mV/V	2.0 ± 0.2
excitation voltage	Vdc	9 ~ 12
combined error	%FS	± 0.02
zero unbalance	%FS	± 2
non-linearity	%FS	± 0.02
hysteresis	%FS	± 0.02
repeatability	%FS	± 0.01
creep	%FS/30min	± 0.02
input resistance	Ω	406 ± 10
output resistance	Ω	350 ± 3
insulation resistance	M Ω	≥ 5000 @ 50 Vdc
operating temperature range	°C	-20 ~ +60
compensated temperature range	°C	-10 ~ +40
temperature coefficient of SPAN	%FS/10°C	± 0.02
temperature coefficient of ZERO	%FS/10°C	± 0.03

Electrical connection:

Excitation+ red Excitation- black Signal+ green Signal- white

Four-core shielded cable with polyethylene. Cable is not connected with elastomer.

Cable length: 3 m

Cable diameter : 5 ±0.2 mm

The cable length could be chose by customer's application.